



高速光耦

High Speed Photo Coupler

QXM6XX(H)

宁波群芯微电子股份有限公司

NINGBO QUNXIN MICROELECTRONICS CO., LTD.

中国 浙江省宁波杭州湾新区玉海东路 68 号

68 Yuhaidong Road, Hangzhou Bay New District, Ningbo, Zhejiang, China

概述 Description

QXM600(H)、QXM601(H)、QXM611(H)内部有一个 850nm 的 AlGaAs LED，其光学耦合到具有选通输出的超高速集成光电探测器。这些器件采用 5 引脚外形封装，符合标准封装外形。

The QXM600(H) QXM601(H) QXM611(H) optocoupler consists of a 850 nm AlGaAs LED, optically coupled to a very high speed integrated photo-detector logic gate with a strobable output. The devices are packaged in a 5-pin small outline package which conforms to the standard footprint.

特性 Features

- 输入-输出隔离电压 ($V_{ISO}=3750$ Vrms)
High isolation voltage between input and output($V_{ISO}=3750$ Vrms)
- 工作温度: $-40^{\circ}\text{C}\sim+125^{\circ}\text{C}$
Operating Temperature: $-40^{\circ}\text{C}\sim+125^{\circ}\text{C}$
- 符合加强绝缘标准
Meet reinforced insulation standards
- 符合安规标准: UL 1577, VDE DIN EN60747-5-5 (VDE 0884-5) , CQC11-471543-2022
Meet Safety standard : UL 1577, VDE DIN EN60747-5-5 (VDE 0884-5) , CQC11-471543-2022

应用 Applications

- 接地回路消除
Ground loop elimination
- LSTTL 转 TTL, LSTTL 或 5V CMOS
LSTTL to TTL, LSTTL or 5-volt CMOS
- 线路接收器, 数据传输
Line receiver, data transmission
- 开关电源
Switching power supplies
- 计算机外围接口
Computer-peripheral interface

真值表 Truth table

LED	VO
OFF	H
ON	L

封装和原理图 Package and Schematic Diagram

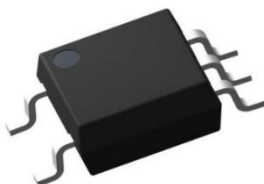

SOP5

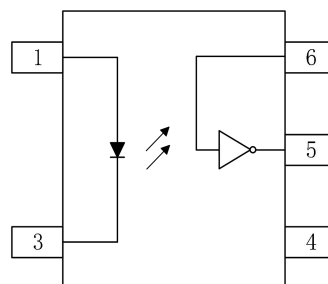

Pin Configuration

1. Anode
3. Cathode
4. GND
5. VO
6. VCC

注: 在引脚 4 和 6 之间必须连接一个 0.1uF 的旁路电容器。

Note: 0.1uF bypass capacitor must be connected between pins 4 and 6.



产品型号命名规则 Order Code

QX M6XX - UN Y - W (V) (ZZ)

① ② ③ ④ ⑤ ⑥ ⑦

- ① 公司代码 Company Code (QX: 群芯 Qunxin)
- ② 产品系列 Product Series (XX: 00, 01, 11)
- ③ 框架类型 Lead Frame (Cu: 铜框架 Copper)
- ④ 树脂类型 Epoxy (H: 无卤 Halogen-free)
- ⑤ 封装形式 Package (S: SOP)
- ⑥ 器件工作温度范围 Device Operating Temperature Range (H: ~+125°C)
- ⑦ 内部补充代码 Internal Supplementary Code (数字或者空白 Number or None)

印字信息 Marking Information

- 印字中“”为群芯品牌 LOGO
“”denotes LOGO
- 印字中的“XX”代表产品分档: 00、01、11
“XX”denotes the classification: 00、01、11
- 印字中“Y”代表年份; A(2018),B(2019),C(2020).....
“Y”denotes YEAR: A(2018), B(2019), C(2020).....
- 印字中“WW”代表周号
“WW”denotes week's number
- 印字中“N”代表星期几
“N”denotes day of the week
- 印字中的“H”代表无卤
“H”denotes Halogen-free

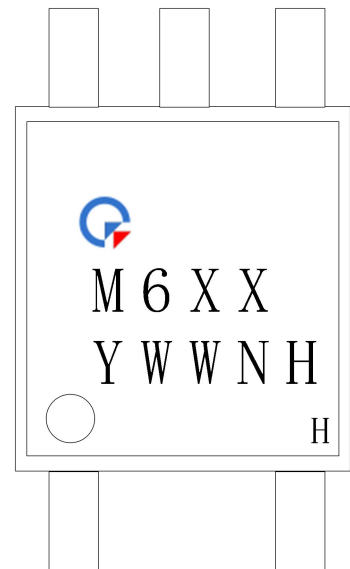

绝缘和安规信息 Insulation and Safety related specifications

项目 Item	符号 Symbol	数值 Value	单位 Unit	备注 Remark
爬电距离 Creepage Distance	L	> 5.0	mm	从输入端到输出端，沿本体最短距离路径 Measured from input terminals to output terminals, shortest distance path along body
电气间隙 Clearance Distance	L	> 5.0	mm	从输入端到输出端，通过空气的最短距离 Measured from input terminals to output terminals, shortest distance through air
绝缘距离 Insulation Thickness	DTI	> 0.4	mm	发射器和探测器之间的绝缘厚度 Insulation thickness between emitter and detector
峰值隔离电压 Peak Isolation Voltage	V_{IORM}	600	V_{peak}	DIN/EN/IEC EN60747-5-5
瞬态隔离电压 Transient isolation voltage	V_{IOTM}	5000	V_{peak}	DIN/EN/IEC EN60747-5-5
隔离电压 Isolation Voltage	V_{iso}	> 3750	V_{rms}	For 1 min

极限参数 Absolute Maximum Ratings ($T_A=25^{\circ}C$)

参数 Parameter	符号 Symbol	额定值 Rating	单位 Unit
发射端 Input	正向电流(平均) DC/Average Forward Input Current	$I_{F(avg)}$	25 mA
	正向峰值电流 (50%占空比, 1ms p.w.) Peak input current (50% duty cycle, 1 ms p.w.)	$I_{F(pk)}$	50 mA
	反向电压 Reverse Voltage	V_R	5 V
	功耗 Power Dissipation	P_D	100 mW
接收端 Output	电源电压 Supply Voltage	V_{CC}	7.0 V
	输出电流 Output Current	I_O	50 mA
	输出电压 Output Voltage	V_O	7.0 V
	集电极功耗 Collector Power Dissipation	P_C	85 mW
工作温度 Operating Temperature	T_{opr}	-40~+125	$^{\circ}C$
存储温度 Storage Temperature	T_{stg}	-55~+125	$^{\circ}C$
焊接温度 Soldering Temperature	T_{sol}	260	$^{\circ}C$

推荐工作条件 Recommended Operating Conditions

参数 Parameter	符号 Symbol	最小值 Min.	最大值 Max.	单位 Unit
电源电压 Supply Voltages	V_{CC}	2.7	5.5	V
低电平输入电流 Input Current, Low level	I_{FL}	0	250	μA
高电平输入电流 Input Current, High level	I_{FH}	6	15	mA
输出上拉电阻 Output Pull-up Resistor	R_L	330	4k	Ω
操作温度 Operating Temperature	T_A	-40	+125	$^{\circ}C$

产品特性参数 Electro-optical Characteristics ($T_A=25^{\circ}C$)

参数 Parameter	符号 Symbol	条件 Condition	最小 Min.	典型 Typ.	最大 Max.	单位 Unit	
发射端 Input	正向电压 Forward Voltage	V_F	$I_F=10mA$	-	1.33	1.8	V
	反向击穿电压 Reverse Breakdown Voltage	BV_R	$I_R=10\mu A$	5	-	-	V
	输入电容 Input Capacitance	C_{IN}	$V=0, f=1MHz$	-	70	-	pF
	正向电压的温度系数 Diode Temperature Coefficient	$\Delta V_F/\Delta T_A$	$I_F=10mA$	-	-1.9	-	mV/ $^{\circ}C$
接收端 Output	高电平电源电流 High Level Supply Current	I_{CCH}	$V_{CC}=5.5V, I_F=0mA$	-	6.0	9	mA
	低电平电源电流 Low Level Supply Current	I_{CCL}	$V_{CC}=5.5V, I_F=0mA$	-	7.5	10	mA
传输特性 Transfer Characteristics	高电平输出电流 HIGH Level Output Current	I_{OH}	$V_{CC}=5.5V$ $V_O=5.5V$ $I_F=0mA$	-	2.1	30	μA
	低电平输出电压 LOW Level Output Voltage	V_{OL}	$V_{CC}=5.5V$ $I_F=5mA$ $I_{OL}=13mA$	-	0.4	0.6	V
	输入阈值电流 Input Threshold Current	I_{TH}	$V_{CC}=5.5V$ $I_{OL}=13mA$ $V_O<0.6V$	-	2.4	5	mA
隔离电压 Isolation Voltage	V_{ISO}	$R_H<50\%$ $T_A=25^{\circ}C$ $I_{I-O}\leq 50\mu A$	3750	-	-	V_{RMS}	
隔离电阻 Isolation Resistance	R_{I-O}	$V_{I-O}=500V$	-	10^{12}	-	Ω	
隔离电容 Isolation Capacitance	C_{I-O}	$f=1MHz$	-	0.6	-	pF	

开关特性 Switching Specification ($T_A=25^\circ\text{C}, I_F=7.5\text{mA}, V_{CC}=5.0\text{V}$)

参数 Parameter	符号 Symbol	条件 Condition	最小 Min.	典型 Typ.	最大 Max.	单位 Unit	
输出高电平传播延迟 Propagation Delay Time to High Output Level	T_{PLH}	$C_L=15\text{pF}$ $R_L=350\Omega$ $T_A=25^\circ\text{C}$	-	41	100	ns	
输出低电平传播延迟 Propagation Delay Time to Low Output Level	T_{PHL}		-	50	100	ns	
脉宽失真 Pulse Width Distortion	$ T_{PHL}-T_{PLH} $		-	9	35	ns	
输出上升时间(10% - 90%) Output Rise Time (10 to 90%)	t_r		-	40	-	ns	
输出下降时间(90% - 10%) Output Fall Time (90 to 10%)	t_f		-	10	-	ns	
传播延迟偏斜 Propagation Delay Skew	t_{psk}		-	-	40	ns	
输出高电平共模瞬态抑制 Common Mode Transient Immunity at High Output Level	M600	$ CM_H $	$T_A=25^\circ\text{C}, I_F=0\text{mA}$ $ V_{CM} =10\text{V(Peak)}$ $V_{OH}=2.0\text{V}, R_L=350\Omega$	-	-	-	V/ μs
	M601		$T_A=25^\circ\text{C}, I_F=0\text{mA}$ $ V_{CM} =50\text{V(Peak)}$ $V_{OH}=2.0\text{V}, R_L=350\Omega$	5000	-	-	
	M611		$T_A=25^\circ\text{C}, I_F=0\text{mA}$ $ V_{CM} =1000\text{V(Peak)}$ $V_{OH}=2.0\text{V}, R_L=350\Omega$	20000	-	-	
输出低电平共模瞬态抑制 Common Mode Transient Immunity at Low Output Level	M600	$ CM_L $	$I_F=7.5\text{mA}, V_{OL}=0.8\text{V}$ $R_L=350\Omega, T_A=25^\circ\text{C}$ $ V_{CM} =10\text{V(Peak)}$	-	-	-	V/ μs
	M601		$I_F=7.5\text{mA}, V_{OL}=0.8\text{V}$ $R_L=350\Omega, T_A=25^\circ\text{C}$ $ V_{CM} =50\text{V(Peak)}$	5000	-	-	
	M611		$I_F=7.5\text{mA}, V_{OL}=0.8\text{V}$ $R_L=350\Omega, T_A=25^\circ\text{C}$ $ V_{CM} =1000\text{V(Peak)}$	20000	-	-	

典型光电特性曲线 Typical Electro-Optical Characteristics Curves

Fig.1 Low-level output voltage vs. Ambient temperature

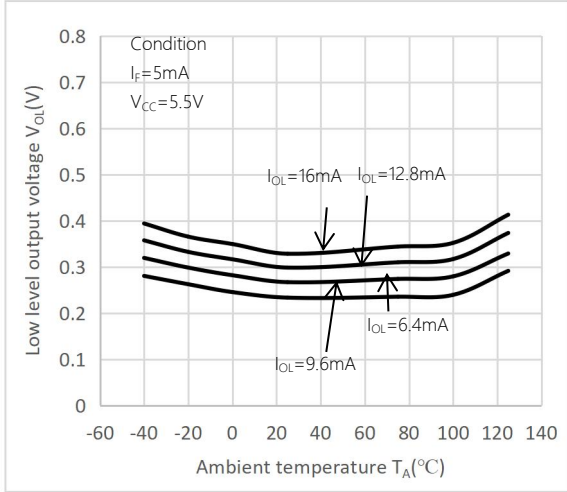

Fig.2 Forward current vs. Forward voltage

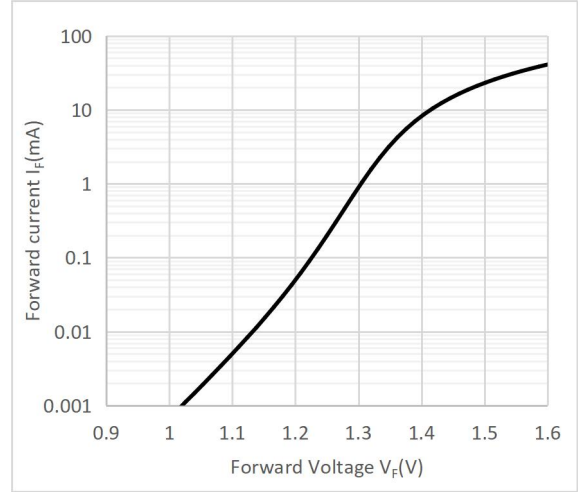

Fig.3 Propagation delay time vs. Forward current

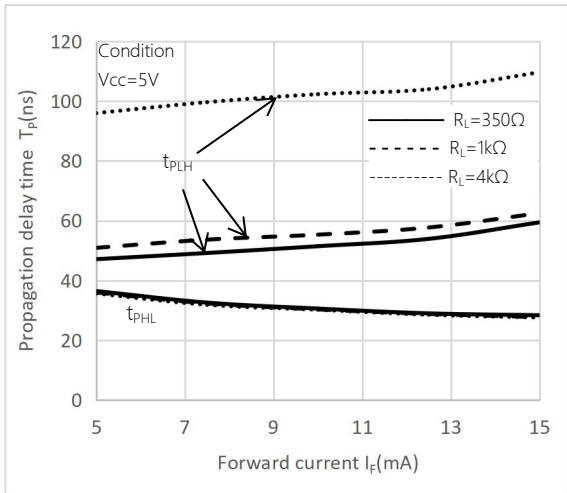

Fig.4 Low-level output current vs. Ambient temperature

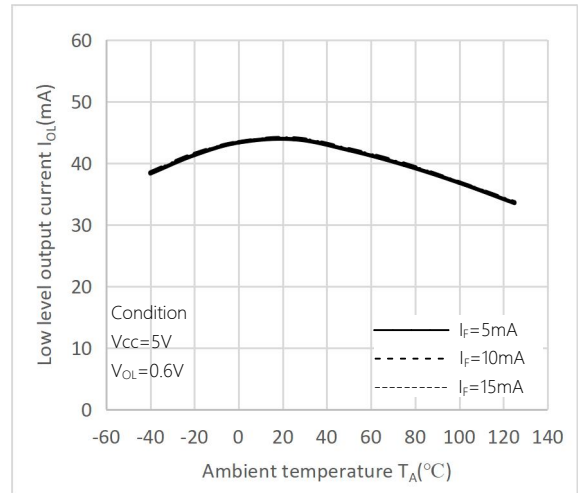

Fig.5 Input threshold current vs. Ambient temperature

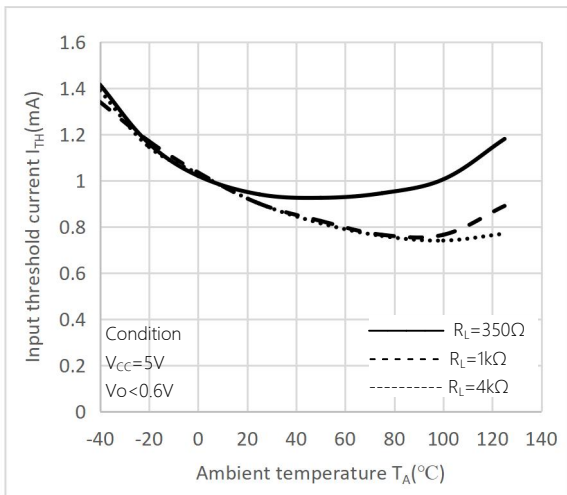

Fig.6 Output voltage vs. Forward current

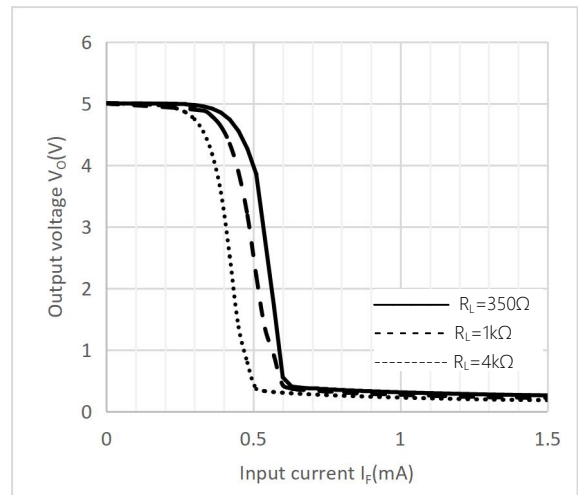

Fig.7 Pulse-width distortion vs. Ambient temperature

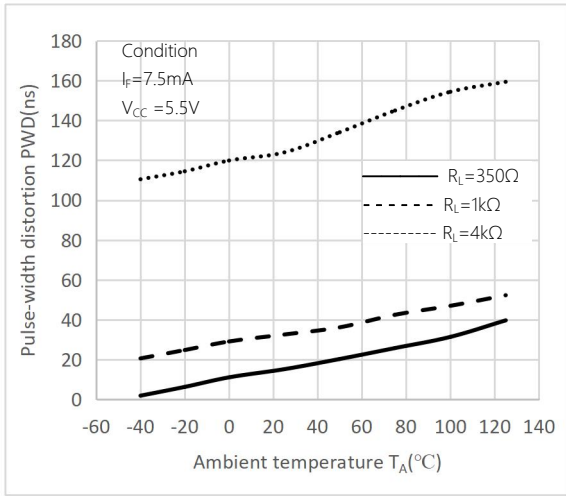

Fig.8 Switching time vs. Ambient temperature

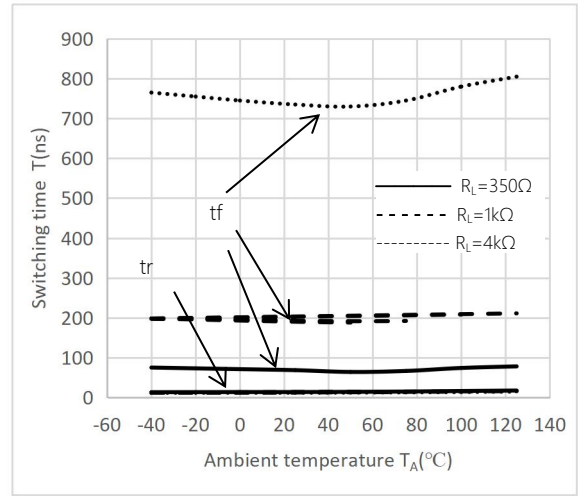

Fig.9 Propagation delay time vs. Ambient temperature

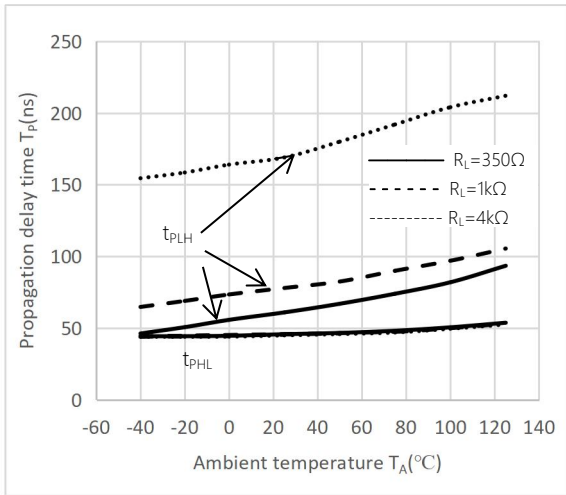
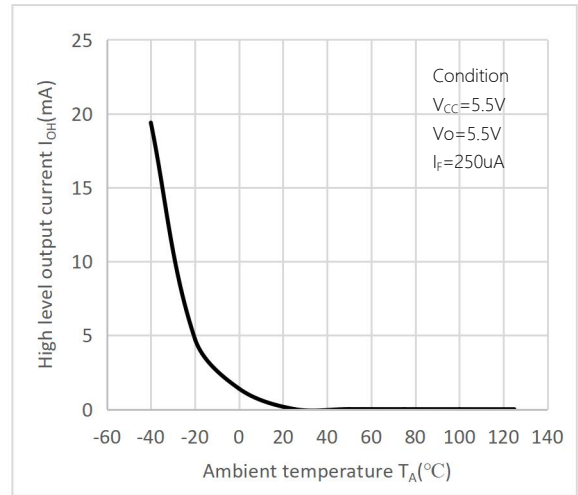
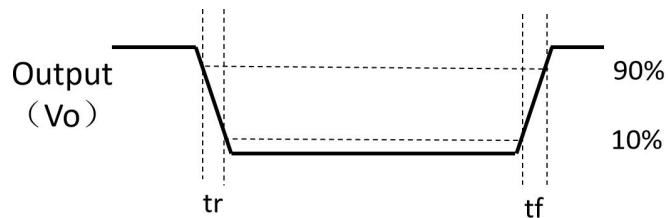
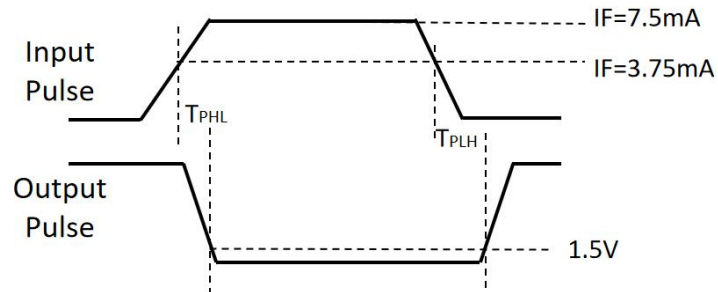
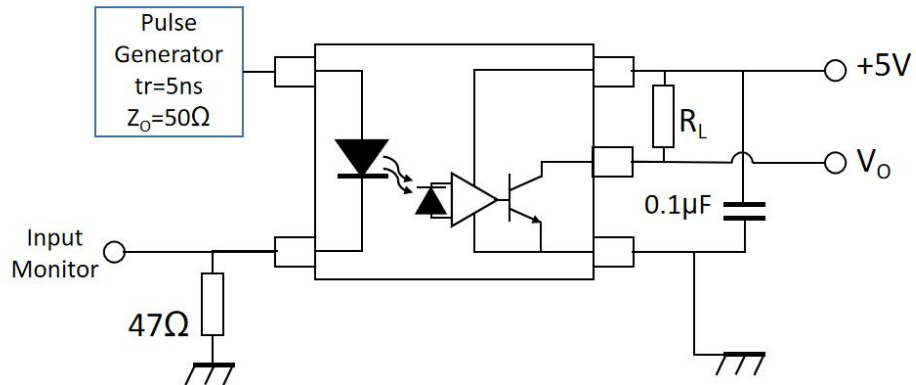

Fig.10 High-level output current vs. Ambient temperature



开关时间测试电路 Switching Time Test Circuit



CMR 测试电路 Test Circuit for Common Mode Transient Immunity

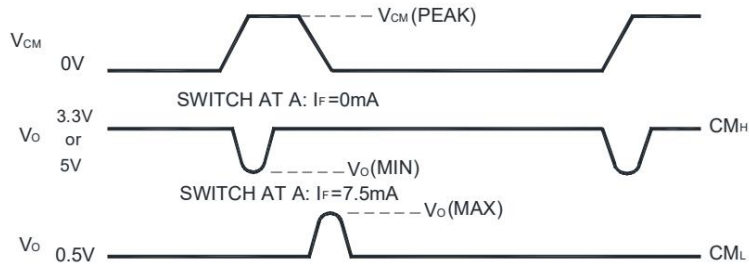
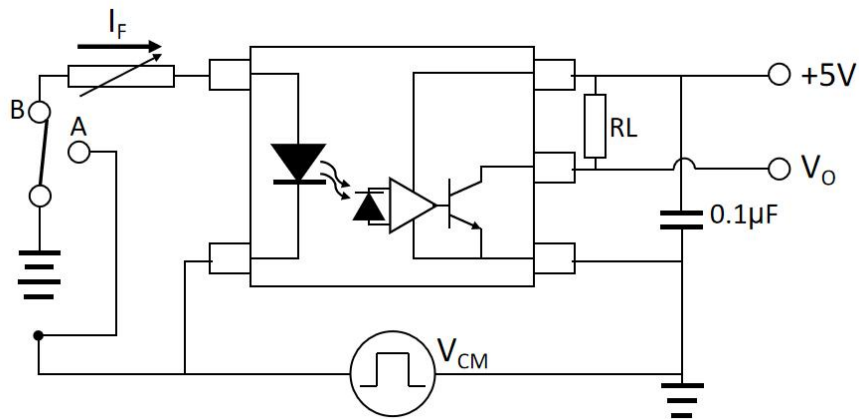

外形尺寸 Outline Dimensions

SOP5

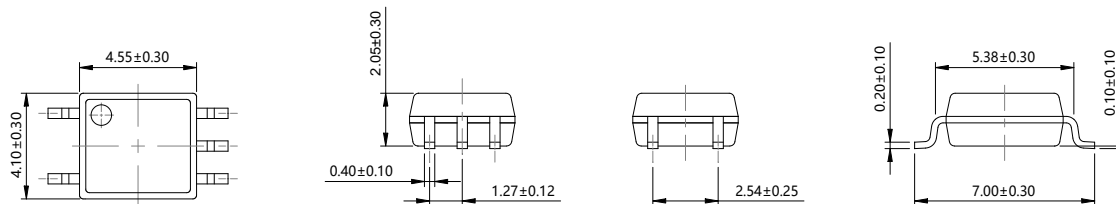

单位 Unit: mm

建议焊盘布局 Recommended Pad Layout

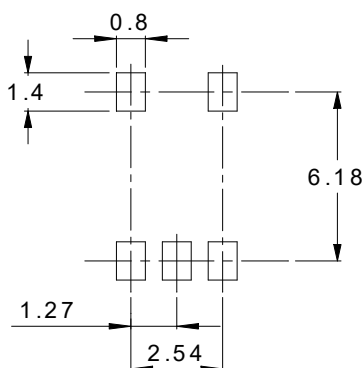

单位 Unit: mm

注：上图为产品正视图。

Note: The picture above is the front view of the product.

回流焊温度曲线图 Solder Reflow Profile

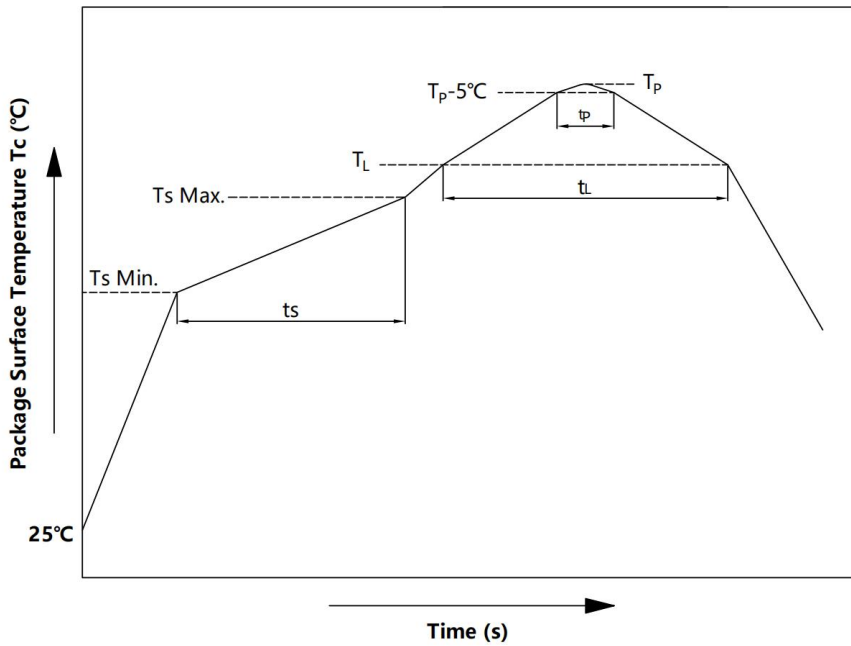

项目 Item	符号 Symbol	最小值 Min.	最大值 Max.	单位 Unit
预热温度 Preheat Temperature	T_s	150	200	$^\circ\text{C}$
预热时间 Preheat Time	t_s	60	120	s
升温速率 Ramp-Up Rate (T_L to T_P)	-	-	3	$^\circ\text{C}/\text{s}$
液相线温度 Liquidus Temperature	T_L	217		$^\circ\text{C}$
时间高于 T_L Time Above T_L	t_L	60	150	s
峰值温度 Peak Temperature	T_P	-	260	$^\circ\text{C}$
T_c 在 (T_P-5) 和 T_P 之间的时间 Time During Which T_c Is Between (T_P-5) and T_P	t_p	-	30	s
降温速率 Ramp-down Rate (T_P to T_L)	-	-	6	$^\circ\text{C}/\text{s}$

注 Note:

建议在所示的温度和时间条件下进行回流焊，最多不能超过三次；

Reflow soldering is recommended at the temperatures and times shown, no more than three times;

波峰焊温度曲线图 Wave Soldering Profile

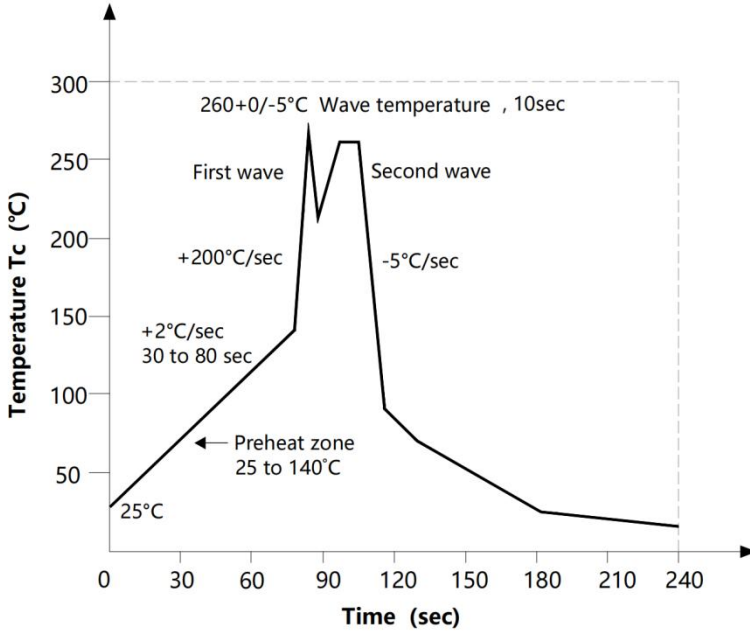

手工烙铁焊接 Soldering with hand soldering iron

- A. 手工烙铁焊仅用于产品返修或样品测试;
Hand soldering iron is only used for product rework or sample testing;
- B. 手工烙铁焊要求: 温度 360°C ± 5°C, 时间 ≤ 3s。
Hand soldering iron requirements: Temperature: 360°C ± 5°C, within 3s.

包装 Packing

■ 汇总表 Summary table

封装形式	包装方式	盘数量	盒数量	箱数量	静电袋规格	盒规格	箱(双瓦楞)规格	备注
SOP5	编带 (φ330mm 蓝)	3k /盘	2 盘/盒	10 盒/箱	450*390*0.1mm	340*60*340mm	620*360*365mm	保护带 200mm (min)
Package Type	Packing Form	Quantity per Reel	Quantity per Box	Quantity per Carton	Antistatic Bag Specification	Box Specification	Carton Specification	Note
SOP5	Reel(φ330mm Blue)	3k pcs/reel	2 reels /box	10 boxes /ctn	450*390*0.1mm	340*60*340mm	620*360*365mm	Guard band 200mm min.

■ 编带包装 Tape & Reel

- 1) 每卷数量: 3000 只。
Qty/reel: 3000 pcs.
- 2) 每箱数量: 60000 只。
Qty/ctn: 60000 pcs.
- 3) 内包装: 每盒 2 盘。
Inner packing: 2 reels/box.
- 4) 示意图 Schematic:

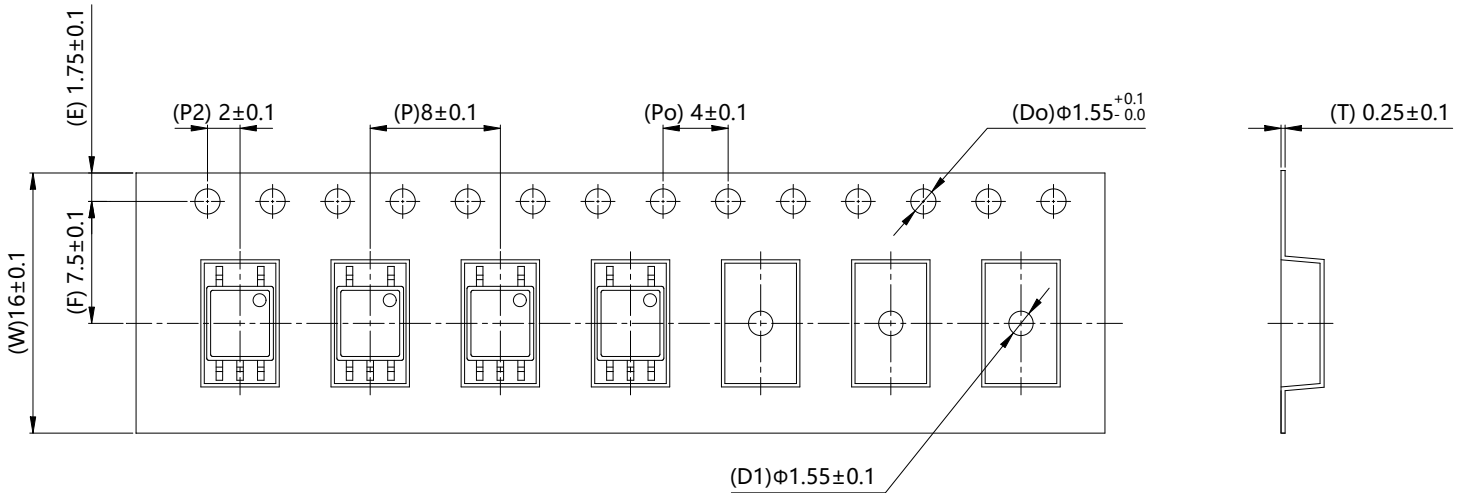

单位 Unit: mm

注意 Attention

- 群芯持续不断改进质量、可靠性、功能或设计，保留此文件更改的权利恕不另行通知。
QUNXIN continuously improve quality, reliability, function and design. We reserve the right to change this document without prior notice.
- 请遵守产品规格书使用，群芯不对使用时不符合产品规格书条件而导致的质量问题负责。
Please use in accordance with the product specification. QUNXIN is not responsible for the quality problems caused by non-compliance with the product specifications.
- 对于需要高可靠性或安全性的设备/装置需求，请联系我们的销售人员。
For equipment/devices requiring high reliability or safety, please contact our sales representatives.
- 当需要用于任何“特定”应用时，请咨询我们的销售人员。
When requiring a device for any “specific” application, please contact our sales in advice.
- 如对文件中表述的内容有疑问，欢迎联系我们。
If you have any questions about the contents of the document, please contact us.